



Date Code Label
Here

Owner's Manual for 36-volt e-Bike



NOTE: Please read and understand the **LCD Display G51 User Manual** that comes with this product before your first ride!



This manual contains important safety, assembly, operation and maintenance information.

Please read and fully understand this manual before operation.

Save this manual for future reference.



Always wear approved helmet and safety equipment when using this product.

See back page for Customer Service Information

HUFFY

© Copyright Huffy Corporation 2025



Owner's Manual Index

Safety and Warnings2-7

Bike ID and Sizing.....8

Parts and Assembly9-19

Operating your e-Bike..... 20-29

Maintenance and Service 30-38

- General Info, Battery Storage, Replacement and Disposal

Troubleshooting39

Warranty40

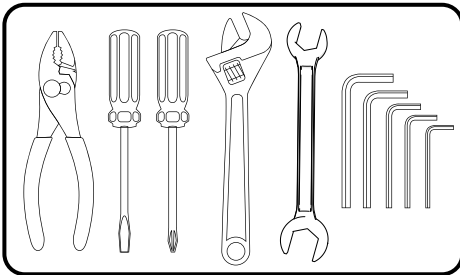

**Tools Recommended:
Gather these tools for quick
assembly.**

(Metric Wrenches)



IMPORTANT! Before using the unit for the first time fully charge the Battery. Battery Charger will shut off when Battery is fully charged, but **never charge longer than 12 hours.**



Multilingual Online Manuals
Manuales multilingües en línea
多語言線上手冊
Многоязычные онлайн-руководства
מאטליינגוואל אָנגלייך מאַניוואַל
বহুভাষিক অনলাইন ম্যানুয়াল
다국어 온라인 매뉴얼
Manyèl sou entènèt plizyè lang
Manuali online multilingue
أدلة متعددة اللغات على الإنترنت
Wielojęzyczne podręczniki online
Manuels multilingues en ligne
كثير لسانی آن لائن دستور العمل

MEANINGS OF WARNINGS:



This symbol is important. See the word "**CAUTION**" or "**WARNING**" which follows it. The word "**CAUTION**" is before mechanical instructions. If you do not obey these instructions, mechanical damage or failure of a part of the bicycle can occur. The word "**WARNING**" is before personal safety instructions. If you do not obey these instructions, injury to the rider or to others can occur.

Riding an e-bike is similar to riding a regular bike but offers a motor that provides assisted power when pedalling.



WARNINGS:

- **When mounting your e-bike**, always apply full front and rear brake lever pressure to keep the unit from moving while mounting and do not put feet on the pedals until you are sitting on the seat.
- **Your e-bike travels at higher speeds** than most riders are used to when pedaling a traditional bike. It is very important that you are aware of your surroundings and obstacles around you and be extra careful when you first start moving. It's important to watch the path surface you are on which can cause tires to slip or flatten.
- **An electric bike is heavier** and requires more time to stop due to weight and faster speeds. Practice starting, riding and stopping in a closed space with no other vehicles and always ride with hands near the brake levers.
- **Before riding**, familiarize yourself with the products operation.
- Do not become distracted by the Display. Change Display settings only when stopped.
- Never ride at speeds faster than you are comfortable with.
- Always start riding with the lowest assist speed.
- Avoid riding this product on wet, frozen, oily or unpaved surfaces or under the influence of drugs and/or alcohol. Avoid uneven surfaces, potholes, surface cracks and obstacles.
- Avoid riding in rain and wet weather and always store e-bike indoors.
- **Always obey State and Local Laws when using this product.** Serious injury can result from the unsafe operations of this vehicle.
- This product is not designed to be jumped. If jumped, even from the curb, The e-bike Frame could break causing serious injury or death. If jumped, the warranty is void.

e-Bike Range:

- Higher assist setting will shorten the distance your e-bike can travel.
- Always keep tires at proper inflation pressure (shown on side walls).
- Heavier riders will shorten riding range.
- Hills or rough terrain will shorten riding range.
- Starting and stopping effects riding range.
- Always fully charge your e-Bike before each ride.

This "Class 2" e-Bike complies with Federal Governments guidelines, with regard to total watts and top speed.



WARNING - TO AVOID SERIOUS INJURY:

IMPORTANT SAFETY INSTRUCTIONS

Failure of the rider to obey the following Safety Warnings can result in serious injury or death. Check local laws governing the use of electrical vehicles.

- **ADULT RIDERS ONLY.**
- **SUPERVISION NECESSARY WHEN USED NEAR CHILDREN.**
- **DO NOT USE THE VEHICLE IN AN UNSAFE MANNER OR AT AN UNSAFE SPEED. Not intended for jumps - this can damage the product.**
- **CHOKING HAZARD:** Small parts, adult assembly required.
- Before using this product, fully understand the controls and safety issues. Riders must demonstrate the capability and skill to handle the vehicle and operate its controls to avoid falls or collisions.
- Obey all traffic regulations, signs, and signals.
- Before each ride, check that the steering system is correctly adjusted and that all connection components are firmly secured and not broken.
- While using the product, keep hands and fingers away from wheels and other moving parts to avoid danger of pinching or entrapment.
- Brake will get hot from continuous and heavy use. Do not touch after braking.
- Riders should always wear a properly fitted helmet that complies with U.S. Consumer Product Safety Commission (CPSC) Standard 16 CFR 1203 or equivalent standard for your country.
- **Always wear shoes.** Gloves, knee and elbow pads recommended.
- Ride on the correct side of the road, in a single file, and in a straight line.
- There are additional hazards of using the vehicle in areas other than private grounds.
- If possible, avoid riding at night, dusk, dawn and any other time of poor visibility.
- **IF YOU MUST RIDE AT NIGHT OR AT TIME OF POOR VISIBILITY:**
 - Use a correctly installed headlight and taillight.
 - Headlights are required by all states for nighttime riding and taillights are required in some states.
 - Battery-powered lights or flashing safety lights are also recommended.
- **MAKE YOURSELF MORE VISIBLE TO MOTORISTS.**
 - **Reflectors:** For your own safety, do not ride the bicycle if the reflectors are incorrectly installed, damaged, or missing. Make sure the front and rear reflectors are vertical. Do not allow the visibility of the reflectors to be blocked by clothing or other articles. Clean the reflectors, as necessary, with soap and a damp cloth.
 - Wear light-colored or reflective clothing, such as a reflective vest and reflective bands for your arms and legs.
 - Use reflective tape on your helmet.
- **USE EXTRA CAUTION IN WET WEATHER:**
 - Ride slowly on damp surfaces because the tires will slide more easily.
 - Allow increased braking distance in wet weather.
- **AVOID HAZARDS TO PREVENT LOSS OF CONTROL OR DAMAGE TO YOUR WHEELS:**
 - Be aware of drain grates, soft road edges, gravel or sand, pot holes or ruts, wet leaves, or uneven paving.

! WARNING - TO AVOID SERIOUS INJURY:

- Cross railroad tracks at a right angle to prevent the loss of control.
- **DO NOT CARRY ANY PASSENGERS.**
- Do not carry any items or attach anything to your bicycle that could hinder your vision, hearing, or control.
- Do not ride with both hands off the handlebar.
- Do not tow or push the product.
- Do not tow anything behind the product.
- Do not modify the product.
- Replace worn or broken parts immediately with original equipment.
- If anything does not operate properly, discontinue use.
- **DO NOT TAMPER WITH THE ELECTRICAL SYSTEM:** Doing so may create a short, causing the fuse to trip or other damage including fire.
- **Risk of Fire:** Do not bypass fuse. Replace only with original size and type.
- The supply terminals are not to be short-circuited.
- Non-rechargeable batteries are not to be recharged.
- Batteries are to be inserted with the correct polarity.
- Rechargeable batteries are only to be charged by adults.
- The battery chargers used with the product are to be regularly examined for damage to the cord, plug, enclosure and other parts, and in the event of such damage, they must not be used until the damage has been repaired.
- Changes or modifications to this unit not expressly approved by the party responsible for compliance could void the user's authority to operate the equipment.
- Do not use the vehicle in unsafe conditions such as snow, rain, loose dirt, mud sand or fine gravel. This may result in unexpected action such as tip over and skidding. Using the vehicle in loose dirt, mud, sand, or fine gravel may damage the electronics and gear box inside the vehicle.
- Do not overload the vehicle.
- Do not drive in very hot weather, components may overheat. Do not allow water or other liquids to come in contact with the battery or other electric components.
- Do not make modifications to the motor to allow it to exceed original power output wattage and speeds.
- The A-weighted emission sound pressure level at the driver ears is less than 70 dB(A).

SAVE THESE INSTRUCTIONS

ALWAYS WEAR YOUR HELMET WHEN RIDING THIS PRODUCT!

Always read the user manual that comes with your helmet to make sure it is fitted and attached properly to the wearer's head according to the fitting instructions described in the user manual.

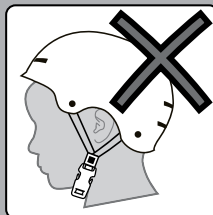
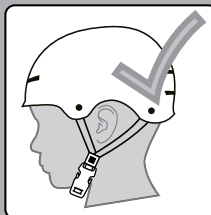

Lithium-Ion Battery & Charger Warnings:



The following safety hazards may result in serious injury or death to the user of the vehicle:

- Battery Charger for Indoor use only. Use of a battery or charger other than the supplied rechargeable battery and charger may cause a fire or explosion. Only use the supplied rechargeable battery (or lead-acid or lithium suitable replacement) and charger with the vehicle.
- Using the rechargeable battery and charger for any other product may result in overheating, fire or explosion. Never use the rechargeable battery and charger with another product.
- Explosive gases are created during charging. Charge the battery in a well ventilated area.
- Do not charge the battery near heat or flammable materials.
- All large lithium batteries are a potential fire risk and should be charged in a safe place, preferably in the middle of a garage floor.
- Never charge a lithium battery unsupervised.
- Only an adult who has read and understands the safety warnings should handle, charge or recharge of the battery.
- Contact between the positive and negative terminals may result in fire or explosion. Avoid direct contact between the terminals. Picking up the battery by the wires or charger can cause damage to the battery and may result in a fire. Always pick up the battery by its case or handles.
- Battery must be handled by adults only. Liquids on the battery may cause fire or electric shock. Always keep all liquids away from the battery and keep the battery dry.
 - Contact or exposure to battery leakage may cause serious injury. If contact or exposure occurs immediately call your physician. If the chemical is on the skin or in the eyes, flush with cool water for 15 minutes. If the chemical was swallowed, immediately give the person water or milk. Do not give water or milk if the patient is vomiting or has a decreased level of alertness. Do not induce vomiting.
- Battery Posts, terminals and related accessories contain lead and lead compounds (acid), chemicals known to cause cancer, reproductive harm and are toxic and corrosive. Never open the battery.
- Tampering or modifying the electric circuit system may cause a shock, fire or explosion and permanently damage the system. Exposed wiring and circuitry in the charger may cause electric shock. Always keep the charger housing closed.
- Non-rechargeable batteries are not to be recharged.
- Batteries are to be inserted with the correct polarity.
- The supply terminals are not to be short-circuited.
- Batteries are only to be charged by adults.
- The battery chargers used with the product are to be regularly examined for damage to the cord, plug, enclosure and other parts, and in the event of such damage, they must not be used until the damage has been repaired.
- Recommended charging temperature: 32 °F to 112 °F (0 °C to +45 °C)
- Recommended riding temperature: -5 °F to 105 °F (-20 °C to +40 °C)
- Charger model: DPLC084V42Y made by D-power

Owner's Bicycle Identification Record

NOTE: This information is only available on the bicycle itself.

Each bicycle has a Recovery Code stamped into the frame. The Recovery Code ① can be found on the bottom of the crank housing as shown.

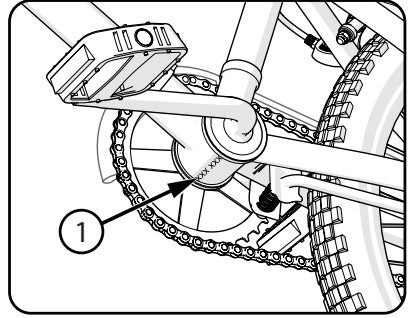

Write this number below to keep it for future reference.

If the bicycle is stolen, give this number and a description of the bicycle to the police. This will help them find the bicycle.

Recovery Code:

Purchase Date:

Model Name:

Fitting the Rider to the Bicycle

A bike which you ride only on paved surfaces, should give you a minimum stand-over height clearance ① of 5 cm (2 in). A bike that you'll ride on unpaved surfaces should give you a minimum of 7.5 cm (3 in) of stand-over height clearance. And a bike that you'll use off road should give you 10 cm (4 in) or more of clearance.

NOTE: See Assembly sections for Seat adjustment.

Adjust the seat height so that you can put the heel of one foot on a pedal with leg extended straight **A** - and so the opposite foot can reach the ground with tip of foot **B**. This will give your knees a slight bend when pedalling with the ball of the foot.

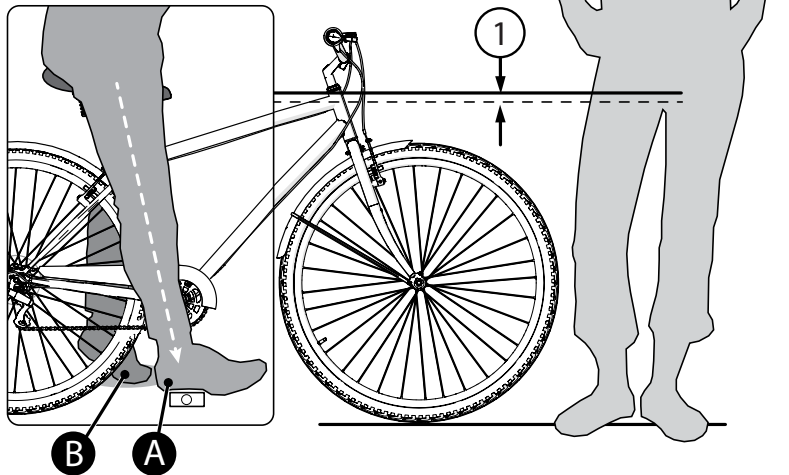

Introduction to Assembly

This Owner's Manual may be made for several different style products.

- Some illustrations may vary slightly from the actual product.
- Follow instructions completely.
- If the product has any parts that are not described in this manual, look for separate "Special Instructions" that are supplied with the unit.
- All features, components and accessories are not included on all models.
- Use the Index page to locate specific sections of this manual.
- Please read through this entire manual before beginning assembly or maintenance.
- If you are not confident with assembling this unit, contact customer service.

 **WARNING:** Keep small parts away from children during assembly.

NOTE: All of the directions (right, left, front, rear, etc.) in this manual are as seen by the rider while seated.

- Do not dispose of the carton and packaging until you complete the assembly of the product. This can prevent accidentally discarding parts of the unit.

Radio Frequency Information (if applicable)

 **WARNING:** Changes or modifications to this unit not expressly approved by the party responsible for compliance could void the user's authority to operate the equipment.

NOTE: This equipment has been tested and found to comply with the limits for a Class B digital device, pursuant to Part 15 of the FCC Rules. These limits are designed to provide reasonable protection against harmful interference in a residential installation. This equipment generates, uses and can radiate radio frequency energy and, if not installed and used in accordance with the instructions, may cause harmful interference to radio communications.

However, there is no guarantee that interference will not occur in a particular installation. If this equipment does cause harmful interference to radio or television

reception, which can be determined by turning the equipment off and on, the user is encouraged to try to correct the interference by one or more of the following measures:

- Reorient or relocate the receiving antenna.
- Increase the separation between the equipment and receiver.
- Connect the equipment into an outlet on a circuit different from that to which the receiver is connected.
- Consult the dealer or an experienced radio/TV technician for help.

This device complies with Part 15 of the FCC Rules. Operation is subject to the following two conditions:

(1) this device may not cause harmful interference, and **(2)** this device must accept any interference received, including interference that may cause undesired operation.

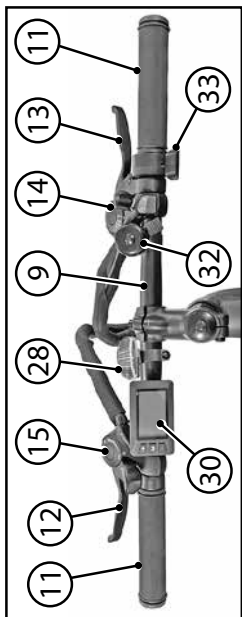

#	Description	#	Description
1	Frame	19	Crank & Spindle Set
2	Stem	20	Pedal (Left & Right Set)
3	Battery	21	Chain
4	Suspension Fork	22	Rear Derailleur
5	Front Wheel Assembly	23	Rear Motor Wheel Assembly
6	Tire (x2)	24	Rear Brake Disc/Caliper
7	Tube (x2)	25	Rear Sprocket Set
8	Front Wheel Retainer and Axle Nut (x2)	26	Front Derailleur
9	Handlebar	27	Rear Reflector
10	Front Brake Disc/Caliper	28	Front Reflector
11	Grip Set	29	Head Set Bearing
12	Handbrake Lever - Left	30	LCD Control Display
13	Handbrake Lever - Right	31	Battery Charger
14	Rear Shifter Control	32	Bell
15	Front Shifter Control	33	Throttle
16	Seat	34	Front Light (some models)
17	Seat Post	*	Kickstand (not shown)
18	Seat Clamp		

NOTE: Please read and understand the **LCD Display G51 User Manual** that comes with this product before your first ride!

Stem Installation (style may vary)

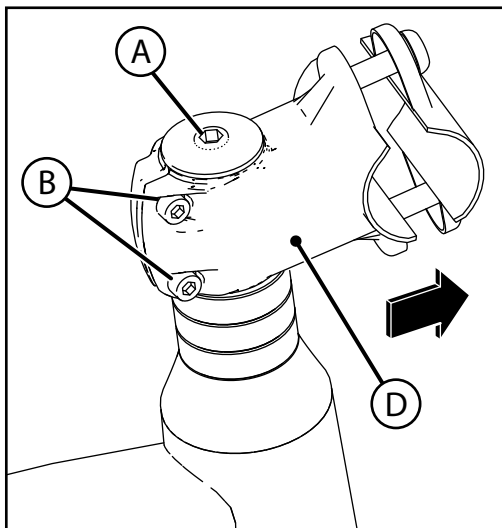
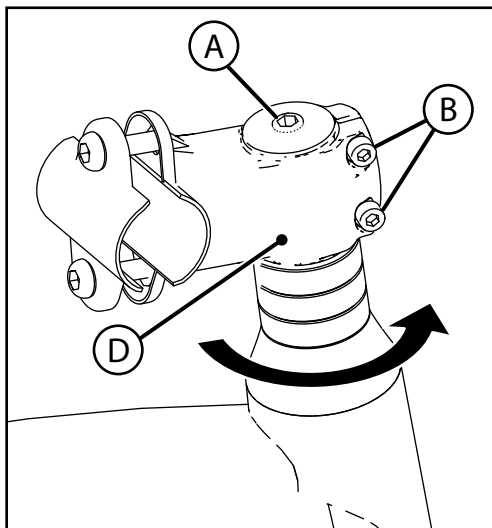

POSITION STEM:

1. While supporting Fork (C), loosen Cap Bolt (A) and Stem Bolts (B) (do not remove bolts), turn Stem 180°.
2. Make sure Fork (C) is pointing **FORWARD**.
3. Align Stem (D) with the Fork (C) and tighten Cap Bolt (A) **FIRST** and Stem Bolts (B) **SECOND** securely.

WARNING:

- Ensure Bolts (A) and (B) are tightened securely so handlebar will not slip and cause damage or loss of control of bike resulting in injury.
- Do not over tighten the stem bolt (A). Over tightening the stem bolt can damage the steering system and cause loss of control.

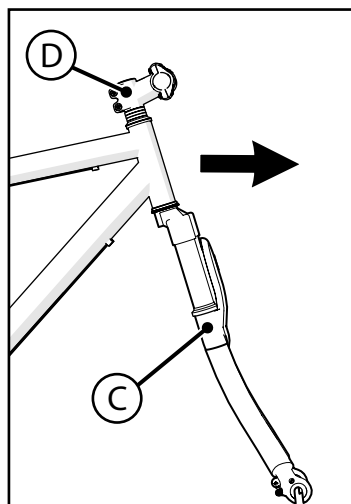

Installing the Front Wheel (various styles)

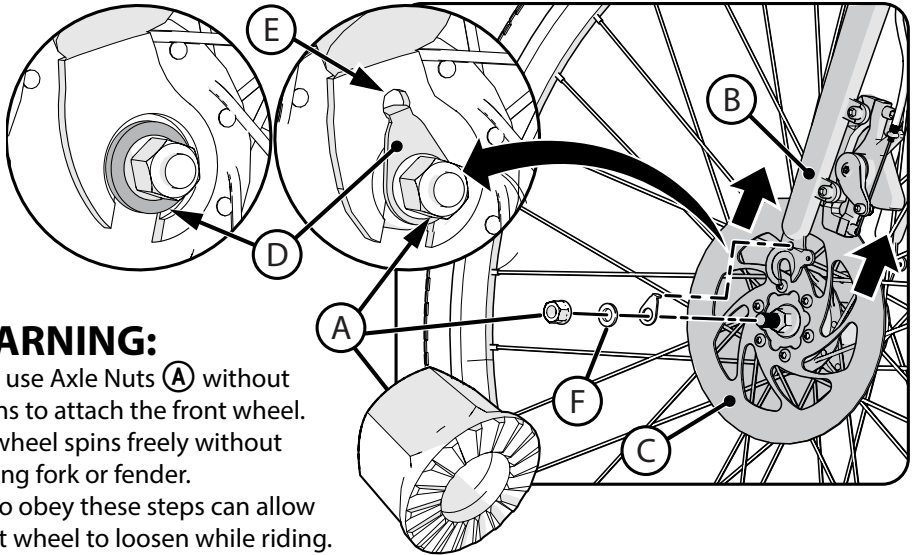

WARNING:

- Do **NOT** use Axle Nuts (A) without serrations to attach the front wheel.
- Ensure wheel spins freely without contacting fork or fender.
- Failure to obey these steps can allow the front wheel to loosen while riding. This can cause injury to the rider or to others.

1. If the Axle Nuts and Washers are already attached to the front wheel axle, remove and set aside.
2. Set the wheel into the Front Fork (B) making sure the Disc Brake (C) fits up into the Disc Brake Caliper. May need to angle wheel 20-30 degrees when placing between fork.

TABBED WHEEL RETAINERS OR FLAT WASHERS (D):

3. Install Wheel Retainers or Washers (D) making sure Wheel Retainer tabs are in the fork (E) tab holes.
4. Install Axle Nuts (A) with serrated surface facing **IN** and Washers (F) if included.
5. With the wheel in the center of the fork, tighten both Axle Nuts securely.



INFLATE ALL TIRES BEFORE RIDING!

- Use a hand or a foot pump to inflate the tires.
- Service station **meter-regulated** air hoses are also acceptable.
- The maximum inflation pressure is shown on the tire sidewall.

Before adding air to any tire, make sure the edge of the tire (the bead) is the same distance from the rim, all around the rim, on both sides of the tire. If the tire does not appear to be seated correctly, release air from the inner tube until you can push the bead of the tire into the rim where necessary. Inflate tire to 50% of the recommended PSI range. Add air slowly and stop frequently to check the tire seating and the pressure, until you reach the correct inflation pressure.

Handlebar Installation - Stem Clamp

TWO BOLT STEM:

1. Remove the Handlebar Clamp and Bolts (A) from stem.
2. Place Handlebar (B) into stem and install Handlebar Clamp and Bolts (A).
3. Place Handlebar (B) into a comfortable riding position.
4. Tighten Handlebar Clamp Bolts (A) securely.

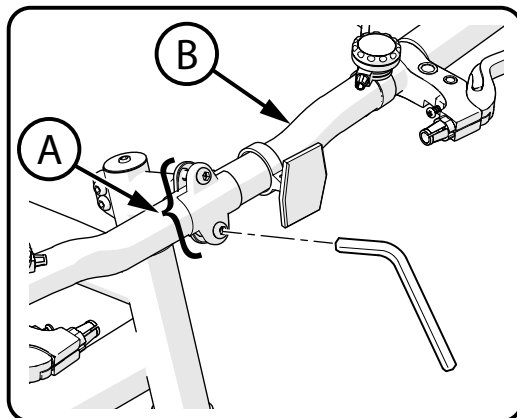

! WARNING: If the handlebar clamp is not tight enough, the handlebar can slip in the stem. This can cause damage to the handlebar or stem, and can cause loss of control.

Handlebar Installation - Steering Alignment

Check Alignment of Handlebars with Steering Wheel:

- Align the Stem (A) with the front wheel and tighten the Stem Bolts (B) securely.
- If necessary, re-adjust Handlebar.

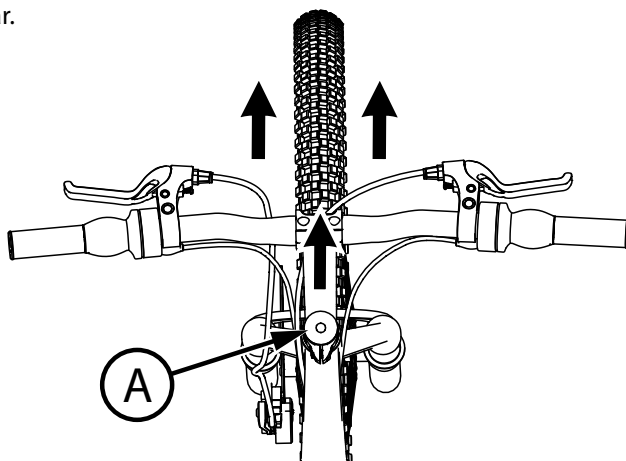
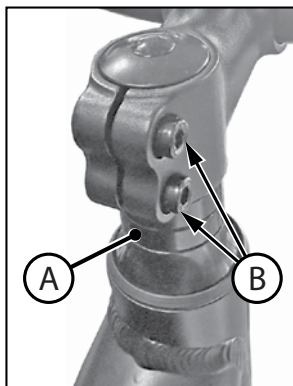

Testing Stem and Handlebar Tightness

TO TEST THE TIGHTNESS OF THE STEM:

- Straddle the front wheel between your legs.
- Try to turn the front wheel by turning the handlebar ①.
- If the handlebar and stem turn without turning the front wheel, realign the stem with the wheel and tighten the stem bolt(s) tighter than before (about 1/2 revolution only at a time) until the handlebar and stem do not turn without turning the front wheel.

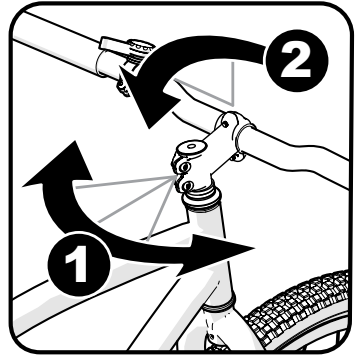

TO TEST THE TIGHTNESS OF THE HANDLEBAR CLAMP:

- Hold the bicycle stationary and try to move the ends of the handlebar up and down ②.

CAUTION: Do not exceed 100 lbs (45 kg) downward force.

- If the handlebar moves, loosen the bolt(s) of the handlebar clamp.
- Put the handlebar in the correct position and tighten the bolt(s) of the handlebar clamp tighter than before.
- If the handlebar clamp has more than one bolt, tighten the bolts equally.
- Do this test again, until the handlebar does not move in the handlebar clamp.

Installing Front Light (if equipped)

With Light facing forward and against Fork Support ①:

1. Insert Bolt and Washer ② through Light Bracket ③ and Fork Support ①.
2. (Some Models) Install Locknut ④ fully and securely so Light does not move.
3. Align Arrows of Front Light Wire Connector to Main Wire Connector and **SNAP** securely together.

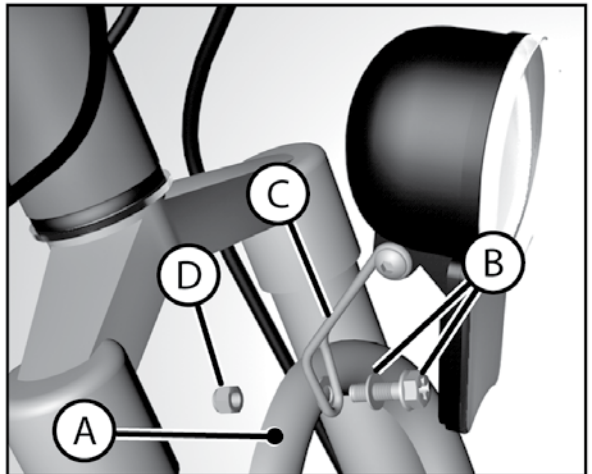

IMPORTANT! Make sure Light is upright and facing forward.

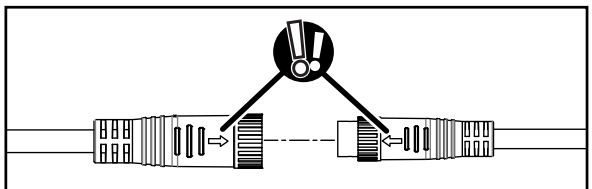

Seat Installation (various models)

⚠ WARNING: To prevent the seat coming loose and possible loss of control, the “MIN-IN” (minimum insertion) mark (A) on the seat post must be **BELOW** the top of the seat tube (B).

STEP 1 - INSERT SEAT POST INTO SEAT TUBE:

- If needed, loosen seat post clamp screw (D) or open the quick release lever (E).
- Point the seat forward and put the seat post (C) into the seat tube (B) with the “MIN-IN” marks BELOW the top of the seat tube as shown.

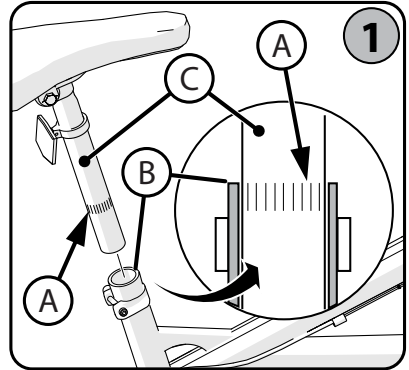

STEP 2 - BOLT SEAT CLAMP: (various models)

- With seat post (C) inserted according to **STEP 1** - Tighten screw (D) securely so seat supports the rider without moving.

STEP 3 - QUICK RELEASE LEVER: (various models)

CAUTION: Operate the quick release lever by **HAND ONLY - DO NOT USE TOOLS.**

1. As needed, open and close the quick release lever (E) with one hand and tighten or loosen the adjusting nut (G) by hand, so that you first feel resistance to the quick release lever when it is in the “**OPEN**” position **1**.
2. Push the quick release lever to the “**CLOSE**” position **2** - It will take **strong force** to clamp securely so that the quick release Lever lays against the seat post clamp (F).

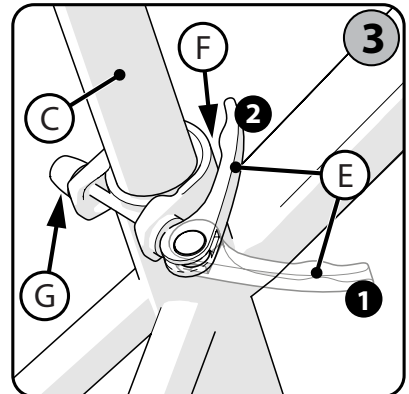
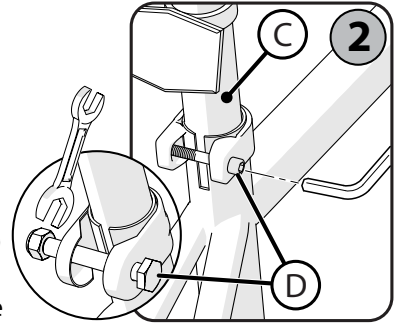

⚠ WARNING: You must use strong force to move the quick release lever securely to the “**CLOSE**” position **2**. This ensures that the seat does not move during normal operation.

NOTE: (I) Suggested Torque 20-22NM - Verify seat does not move while riding.

REFLECTOR: (as equipped)

Position seat post reflector (if equipped) (H) so it points straight backwards. Tighten clamp screw.

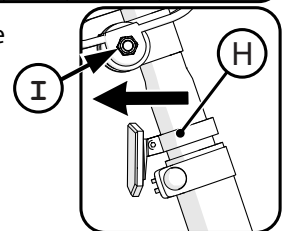

Seat Bolt Saddle Adjustment (various models)

SINGLE BOLT CLAMP:

1. Loosen the clamp bolt (A) sufficiently to allow any serrations (B) on the mechanism to disengage before changing the saddle's angle.
2. With serrations fully re-engaged and saddle in a comfortable riding position, tighten the clamp bolt (A) securely to ensure the saddle will not come loose.

⚠ WARNING: Serrations on the mating surfaces of the clamp can wear with use and adjustment. Check that the clamp is tight and secure before each ride.

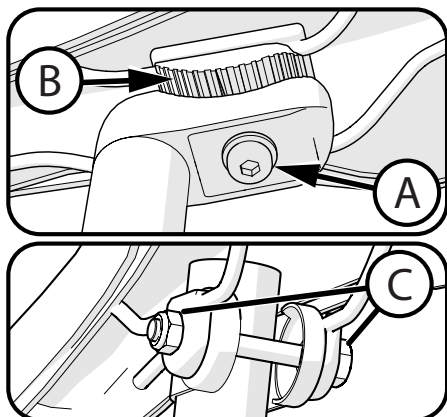

DUAL CLAMP:

3. Loosen clamp bolt/nut (C) as needed and adjust seat to a comfortable riding position.
4. With clamp fully on seat post as shown, tighten bolt/nut (C) securely so that seat does not move when in use.

Testing Seat Clamp and Post Clamp Tightness

To test the tightness of the seat clamp and the post clamp:

- Try to turn the seat side-to-side and to move the front of the seat up and down.

If the seat moves in the seat clamp:

- Loosen the Seat clamp nut.
- Put the seat in the correct position and tighten the seat clamp tighter than before.
- Do this test again, until the seat does not move in the seat clamp.

If the seat post moves in the seat tube clamp:

- Loosen the seat clamp lever.
- Put the seat post in the correct position and tighten the seat clamp nut tighter than before.

If necessary, tighten or loosen hand nut so that quick release tightens securely.

- Do this test again, until the seat post does not move in the seat tube clamp.

Pedal Installation

CAUTION: There is a RIGHT pedal marked **R** and a LEFT pedal marked **L**.

NOTE: A Pedal Wrench is preferred for attaching Pedals. A thin open-end wrench can also be used.

- The pedal marked **R** has right-hand threads. Tighten it in a **clockwise direction**.
- The pedal marked **L** has left-hand threads. Tighten it in a **counterclockwise direction (anti-clockwise)**.
- Turn the right pedal marked **R** into the right side of the crank arm, and the left pedal marked **L** into the left side of the crank arm.

Tighten the pedals:

- Make sure the threads of each pedal are fully into the crank arm.

WARNING: Ensure pedals are secure in crank arms so they will not loosen. Periodically check tightness.

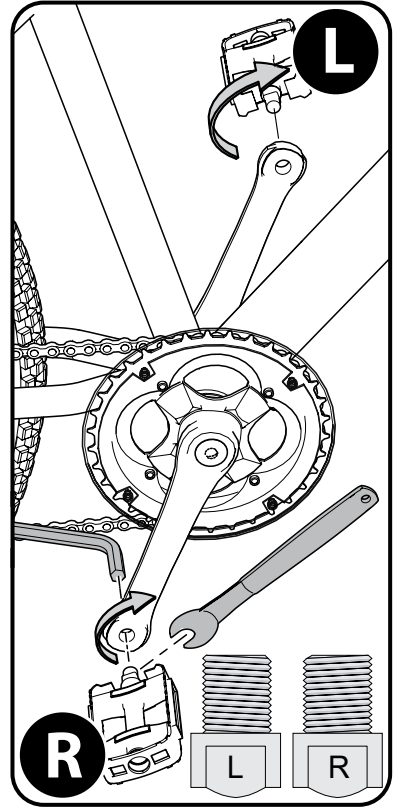

Three-Piece Cranks (various models)

Maintenance: Both Crank Arms **A** were tightened to the spindle **B** at the factory. After riding the bicycle the first few times, make sure the crank arms have not loosened. If either crank arm has loosened during this "break-in" period, re-tighten or have it tightened by a bicycle service shop.

Frequently check the tightness of the crank arms. If loose, tighten or have them tightened by a bicycle service shop.

WARNING: If you ride the bicycle with a loose crank arm, the crank arm may fall off. The spindle may also damage the crank arm.

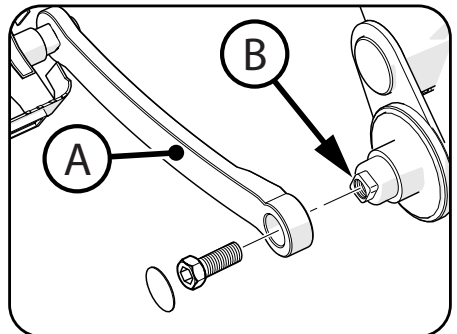

Removing and Installing Battery

REMOVING BATTERY 1:

1. Turn Key (A) fully **right** until top of Battery is loose.
2. Pull top of battery out away from opening and lift out of battery tray.

INSTALLING BATTERY 2:

1. Place bottom of battery into battery tray opening.
2. Lean battery into battery tray - Push fulling into position until battery **snaps** locked into position. Some force will be needed.
3. Turn Key (A) fully **left** to lock.
4. Gently pull out on battery to make sure it does not come lose.

POWER BUTTON:

- When pressing the Power Button (B) indicator will light on by 3 different colors red/green/blue in different battery capacity.
- Use LCD Display to check the battery capacity.
- No light on when charging.

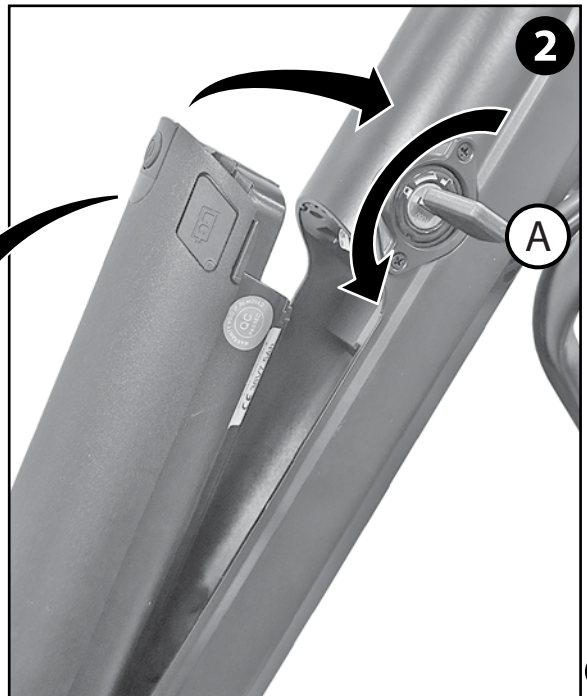
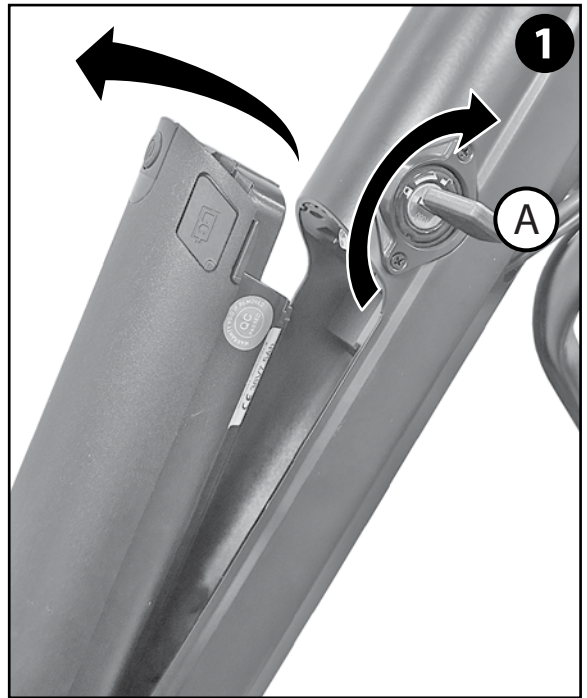
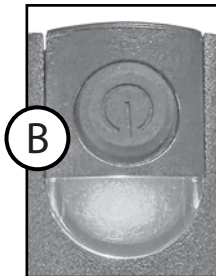

Display User Manual

NOTE: Please read and understand the **Display G51 User Manual** that comes with this product.

User Manual LCD Display G51



1. Exterior Parameters
Casing Material: ABS
Display Material: High Hardness Acrylic (the same hardness value as tempered glass).

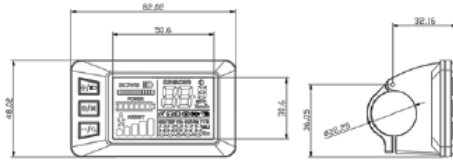

2. Operating Voltage and Connections

a. Operating Voltage: DC24V / 36V Compatible, 36/48V Compatible (set by the control panel). Other operating voltage can be customized.

b. Connections: Standard Connector Type



Controller Connector

Display Output Connector

Coupling Input Connector

Thumb Throttle Control



NOTE:
Throttle will engage when e-bike reaches a minimum speed of 1-3 mph.

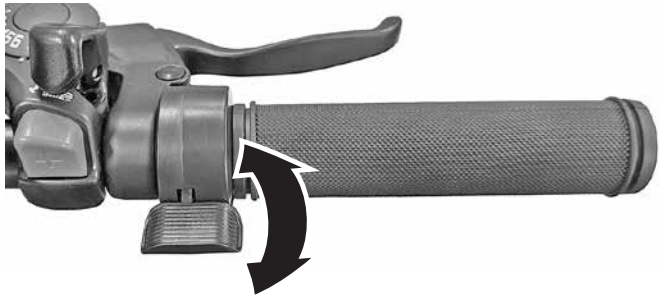

Models that are equipped with Thumb Throttle:

- Press down to increase speed.
- Hold to maintain current speed.
- Release to decrease speed.

WARNING:

- Always ride with a safe distance between you and other vehicles or objects to give yourself adequate room to stop.
- Look ahead and adjust your speed in advance to avoid hard braking.
- Different bikes have different brake systems and different levels of brake power. Be aware of your bicycle's braking power and don't ride beyond it.
- Wet, debris, or uneven pavement will affect how your bike reacts to braking. Take extra care when braking under less-than-ideal road conditions. Allow more time and distance for stopping.

HAND BRAKES:

Operate the hand brake as follows:

NOTE: Before riding, make sure you know which brake lever controls which brake (front or rear). If you have two hand brakes, apply both brakes at the same time.

- The front brake provides more stopping power than the rear, so do not use it too forcefully or too abruptly. Gradually add pressure to both brake levers until you slow to the desired speed or stop.
- If you must stop quickly, shift your weight back as you apply the brakes to keep the rear wheel on the ground.

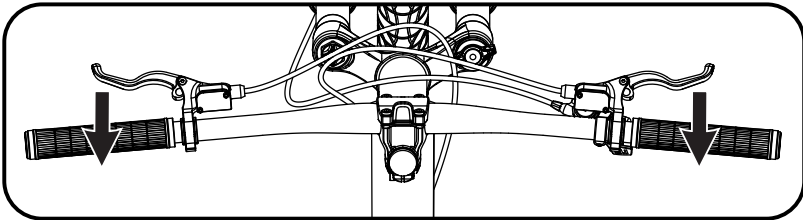

WARNING:

- Brake force applied to the front wheel suddenly or too fully could lift the rear wheel off the ground or cause the front wheel to slide out from under you. This will decrease your control and cause you to fall.

Shift System

PARTS OF THE SHIFT SYSTEM:

- Left-hand Shifter (A) operates the Front Derailleur (B).
- Right-hand Shift Lever (C) operates the Rear Derailleur (D).
- Front Sprocket Set (E).
- Rear Sprocket Set (F).

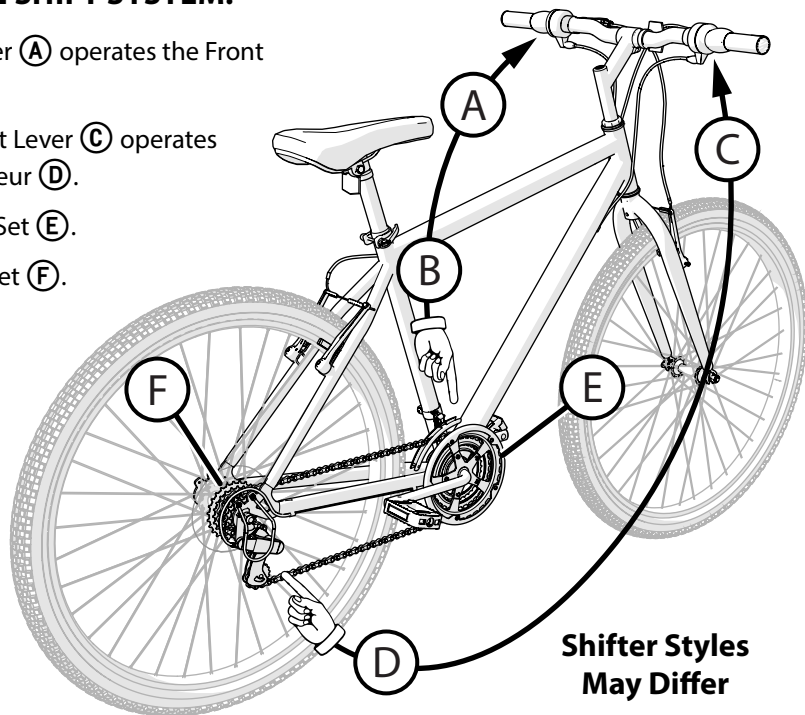

WARNING:

- Never shift a derailleur onto the largest or the smallest sprocket if the derailleur is not shifting smoothly. The derailleur may be out of adjustment and the chain could jam, causing loss of control and injury.
- Never move the shifter while pedaling backward, nor pedal backwards immediately after having moved the shifter. This could jam the chain and cause damage to the bicycle and/or loss of control and injury.

continued >>

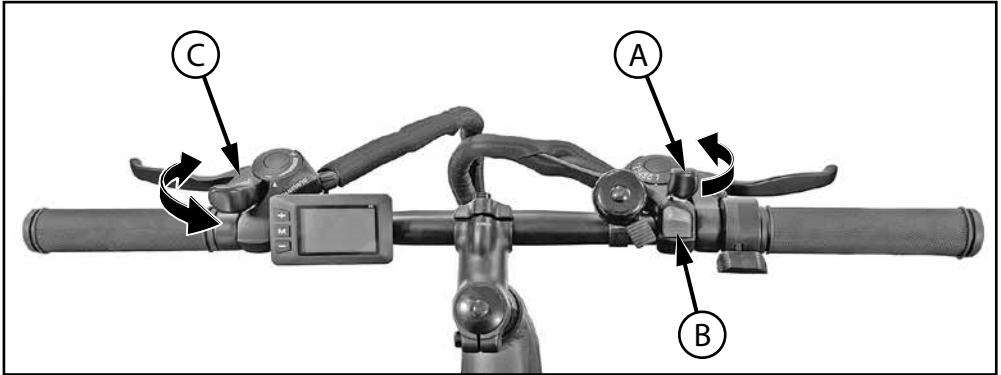

OPERATE THE SHIFT SYSTEM AS FOLLOWS:

SHIFT CONTROL:

1. The rider moves the Right Shift Lever (A) forward to an index position to shift the chain on the rear sprocket to a lower gear.
2. The shift is complete when the Right Shift Lever (A) moves into each position with a “click” sound.
3. Pressing **IN** the Right Shift Button (B) will raise index position and shift the chain on the rear sprocket to a higher gear.
4. The rider moves the Left Shift Lever (C) forward or backward to adjust the front derailleur and shift the chain on the front sprocket to allow for finer tuning.
5. Each shift control pulls a cable wire that is attached to the derailleur.
6. The derailleur moves and guides the chain from one sprocket to another.
7. If there is some chain noise after the shift, move the right shifter lever a small amount to “trim” the rear derailleur.

continued >>

Shift System - continued

CAUTION: Do not force the shift levers. Shift only when pedaling forward and without strong force. Do not backpedal. Backpedaling can cause the chain to come off the sprockets. Backpedaling and shifting while not pedaling can damage the sprockets and stretch the cable wire.

There is no "correct gear" in which to ride the bicycle. The "correct gear" is the one that is comfortable to you.

To select a gear or sprocket combination while riding:

1. While pedaling, shift the chain onto different front and rear sprocket combinations.
2. You will feel a difference in the rhythm and ease of pedaling.
3. Shift the chain to the gear that allows you to pedal at a rhythm and effort that is comfortable to you.
4. When riding uphill or against the wind, you may wish to keep the chain on the smallest front sprocket (A) and shift the chain on the rear sprocket cluster (B).

THESE ARE THE LOWER GEAR COMBINATIONS:

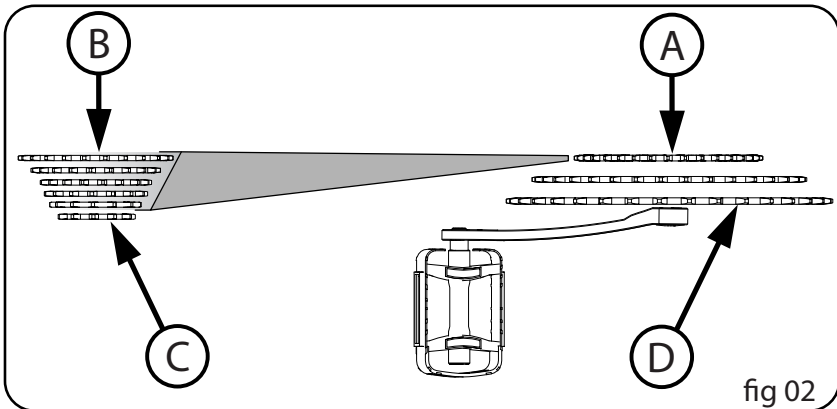

- They allow you to pedal easier and at a faster rhythm, but with less distance traveled per pedal revolution.
- For the best performance in this case, do not use the smallest rear sprocket (C).
- When riding downhill or with the wind, you may wish to keep the chain on the largest front sprocket (D) and shift the chain on the rear sprocket cluster.

continued >>

THESE ARE THE HIGHER GEAR COMBINATIONS:

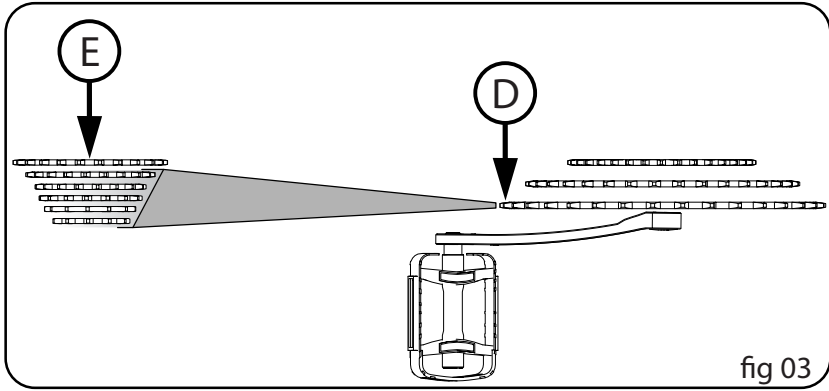

- They allow you to pedal harder and at a slower rhythm, but with more distance traveled per pedal revolution.
- For the best performance in this case, do not use the largest rear sprocket (E).

THESE ARE THE MIDDLE RANGE GEAR COMBINATIONS:

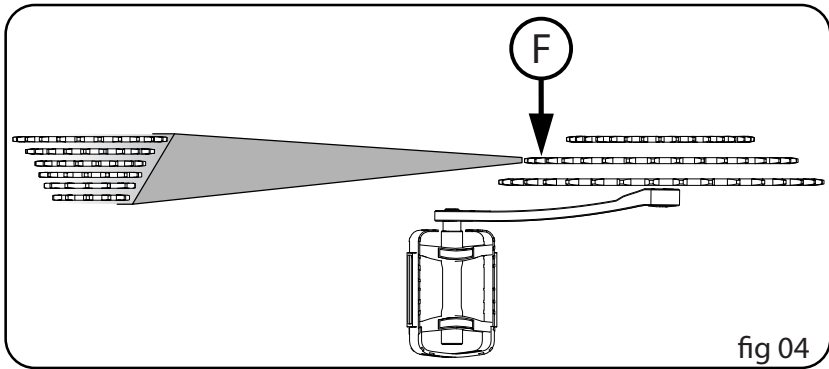

- These overlap some of the higher and some of the lower gear combinations.
- On bicycles with three front sprockets, you may wish to keep the chain on the middle front sprocket (F) and shift the chain on the rear sprocket cluster.

Rear Derailleur Adjustments

The rear derailleur has two adjusting screws. The “low” adjusting screw, sometimes marked **L**, limits how far the rear derailleur and chain can move toward the wheel. The “high” adjusting screw, sometimes marked **H**, limits how far the rear derailleur and chain can move away from the wheel.

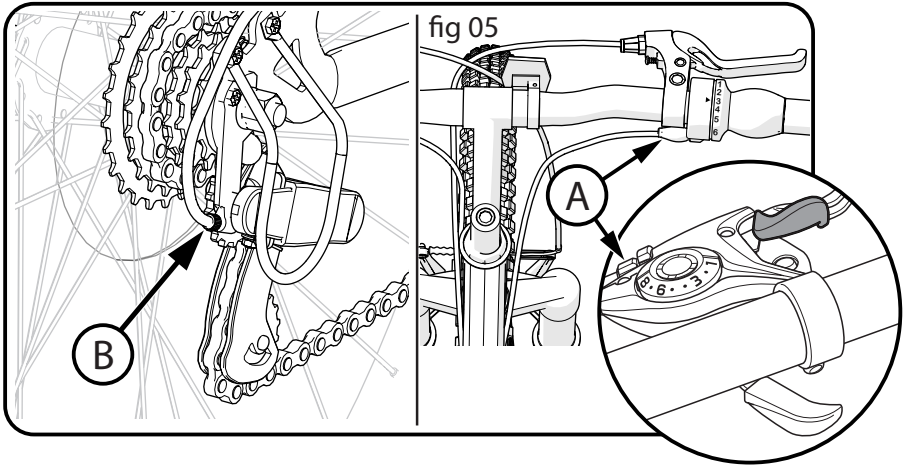

Put the “high” adjusting screw in the correct position as follows:

- Shift the chain onto the smallest rear sprocket. Loosen Nut **C** of the cable clamp.
- Turn the lever Barrel Adjuster **A** and rear Derailleur Adjuster **B** all the way IN (**fig 05**).
- Turn the “high” adjusting Screw **H** so the Jockey Roller **D** is in line with the outside edge of the smallest rear Sprocket **E** (**fig 06**)
- Remove the slack from the cable wire and tighten the Nut of the cable clamp.

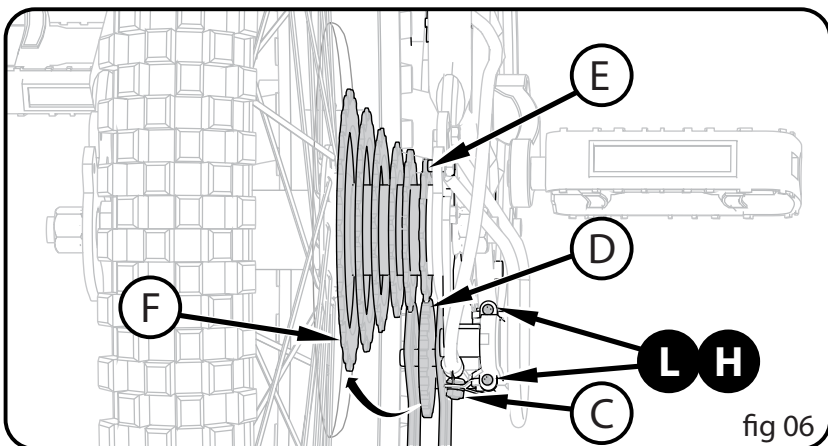

continued >>

Rear Derailleur Adjustments - continued

Put the “low” adjusting Screw in the correct position as follows:

- Shift the chain onto the largest rear Sprocket **(F)**.
- Loosen Nut of the cable clamp.
- Turn the “low” adjusting Screw **(L)** so the Jockey Roller is exactly below the largest rear sprocket. **(fig 06)**
- Tighten the Nut of the cable clamp.

Adjust the Index Shift System:

- Shift the chain onto the smallest rear sprocket.
- Without turning the crank, turn the Right Shift Control **(A)** one “click” rearward - or “click” thumb lever **(fig 07)**.
- Slowly turn the crank forward.
- The chain should move from the smallest rear sprocket to the next larger rear sprocket.
- Turn the Adjusting Barrel **(B)** OUT as needed so the chain moves exactly on to the second rear sprocket and does not rub, jump, or delay.

When adjusted properly, the shift system will operate smoothly with no chain rubbing.

NOTE: If you have trouble, take the bike to a bike shop.

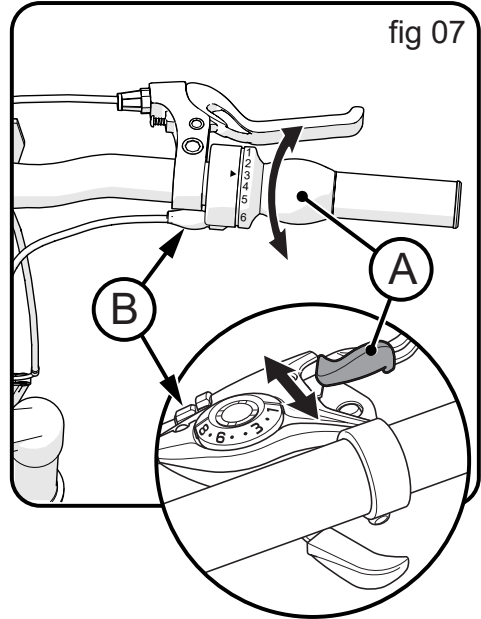

Front Derailleur Adjustments (various models)

These instructions describe most adjustments that the shift system may need. If you can not adjust the shift system using these instructions, have a bicycle service shop do the adjustments that are needed.

The Handlebar Twist Grips (or Thumb Shifts) (**View 1**) control the Shift System. The Left Side **A** shifts the chain on the front sprockets (**View 2**). The Right Side **B** shifts the chain on the Rear Sprocket (**View 3**).

The front derailleur (**View 2**) has two adjusting screws. The “low” adjusting screw, sometimes marked **L**, limits how far the front derailleur and chain can move toward the frame. The “high” adjusting screw, sometimes marked **H**, limits how far the front derailleur and chain can move away from the frame.

Put the “low” adjusting screw **L in the correct position as follows:**

- Shift the chain onto the third largest rear sprocket and the smallest front sprocket.
- Turn the lever Barrel Adjuster **C** all the way IN.
- Loosen Nut **D** of the cable clamp.
- Turn the “low” adjusting screw **L** so the left inside edge of the chain cage **E** and the chain **F** just do not touch.
- Remove the slack from the cable wire and tighten Nut **D** securely.

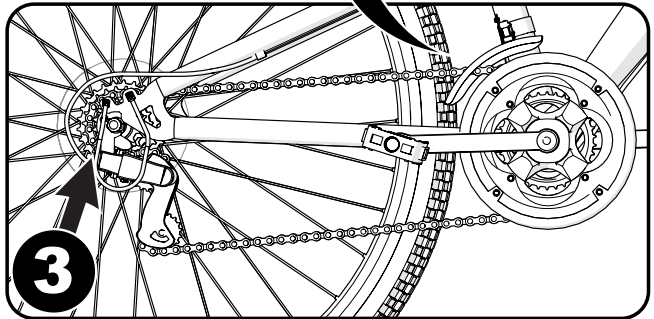
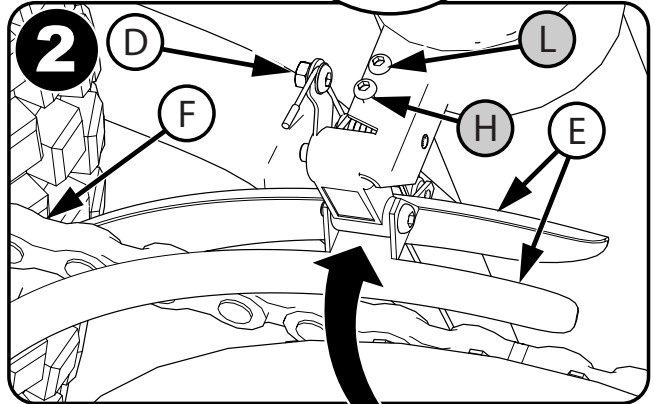
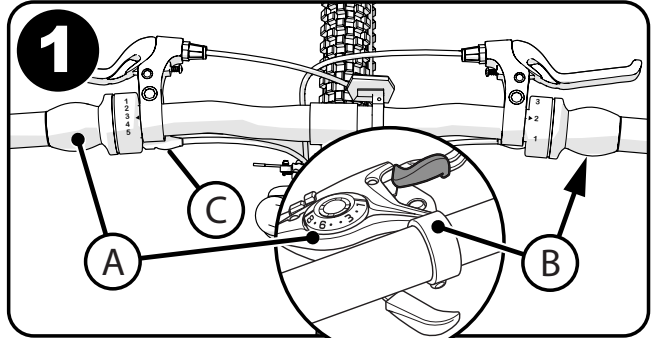

continued >>>

Front Derailleur Adjustments (various models) - continued

Put the “high” adjusting screw  in the correct position as follows:

- Shift the chain onto the largest front sprocket and the smallest rear sprocket.
- Turn the “high” adjusting screw  so the right inside edge of the chain cage and the chain just do not touch.

NOTE: If the shift lever does not move easily:

- If the shift cable seems to stick, lubricate it.
- Do not lubricate the shift control.
- If the shift cable is sharply bent, rusted or has broken strands, replace it.

Perform the “Rear Derailleur Adjustments” if:

- The chain will not shift onto all the rear sprockets.
- The chain comes off the rear sprockets.
- The chain makes noise while on the smallest or largest rear sprocket.
- The rear derailleur rubs the spoke protector.

WARNING:

- The vehicle should be checked for damage, missing or badly worn parts before each use. If any part of the product does not operate properly – discontinue use.
- As with all mechanical components, the bicycle is subjected to wear and high stresses. Different materials and components might react to wear or stress fatigue in different ways. If the design life of a component has been exceeded, it may suddenly fail, possibly causing injuries to the rider. Any form of crack, scratches, or change of coloring in highly stressed areas indicate that the life of the component has been reached and should be replaced.
- Inspect the product frequently. Failure to inspect the product and to make repairs or adjustments, as necessary, can result in injury to the rider or to others. Make sure all parts are correctly assembled and adjusted as written in this manual and any “Special Instructions”.
- Immediately replace any damaged, missing, or badly worn parts with original equipment.
- Avoid wearing loose clothing and items when riding or performing maintenance to reduce risk of entrapment that could result in an injury.
- Keep the product clean and free of dirt, dust and water. This will prolong the useful life of the product.
- Dirty or greasy wheel rims can render your brakes ineffective. To avoid injury, clean frequently, using a clean rag or wash with soapy water, rinse and air dry. Do not clean them with oily or greasy materials.
- High temperatures, intensive use, and impact damage may be invisible to the user and result in injury to rider. If you suspect damage or excess wear to wheel rims, frame, fork, suspension joints (if any), or composite components (if any), seek service from bike shop for repair.
- Make sure all fasteners are correctly tightened as written in this manual and any “Special Instructions”. Parts that are not tight enough can be lost or operate poorly. Over tightened parts can be damaged. Make sure any replacement fasteners are the correct size and type.
- Self-locking nuts and other self-locking fasteners may lose their effectiveness when re-used.
- Check the tightness of the wheels.
- **Always remove the battery** when replacing a component or performing maintenance.
- Periodically check your e-Bike’s wiring and motor condition and mounting.
- Always store your e-Bike indoors. Bike’s left outside in weather can deteriorate very quickly. Prolonged exposure to UV-rays, rain, and outdoor elements may damage the enclosure materials.
- Store your e-Bike in a clean dry environment. Do not cover with plastic which will hold moisture inside and affect your bike’s electrical system.
- Store your battery indoors during cold weather to optimize battery performance.

CLEANING: Do not submerge the drive unit in water or wash with a pressurized hose. Keep all components clean, especially the battery pack contact points. Clean carefully with soft, damp cloth using only mild soap and water.

STORAGE: Always store the battery pack in a cool dry place. Keep it away from sources of heat, such as stoves and heaters. During periods of prolonged storage, battery pack should be charged at least once every 6 months at a minimum of 50% or every 3 months at 40%. Do not charge higher than 60% when storing.

NOTE: Have a bicycle service shop make any repairs or adjustments for which you do not have the correct tools or if the instructions in this manual or any “Special Instructions” are not sufficient for you.

Disc Brake System Adjustment: (various models)

NOTE: For Hydraulic Brakes, see Manufacturer's instructions included with this product.

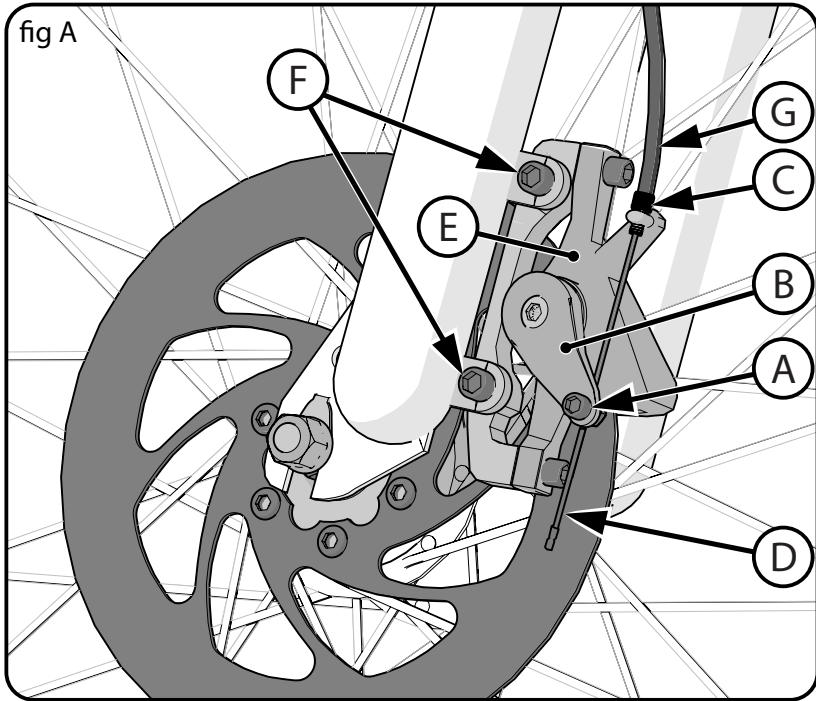

BRAKE ADJUSTMENT (see fig-A):

1. Loosen the Cable Clamp Bolt (A).
2. Push the Brake Arm (B) toward the Adjusting Barrel (C) (this applies the brake).
3. While holding the Brake Arm, pull the slack out of the Cable End (D) (through the Cable Clamp) and tighten the Cable Clamp Bolt (A).

WARNING: Do not over tighten the Cable Clamp. Over tightening the Cable Clamp may cut the Cable and cause injury to the rider or to others.

4. Pull and release the brake lever several times to set the Brake Cable.
5. Spin the wheel. It should spin freely. If the Disc cannot spin freely in the Caliper, the Cable might be too tight. Loosen the Cable Clamp Bolt and allow the brake arm to move away from the adjusting barrel – repeat steps 1 through 4 until the wheel spins freely.

NOTE: An initial gap of 0.3mm (0.01 inch) is recommended.

6. A properly adjusted Caliper is set such that, the pads contact the Disc at approximately 1/3 lever travel and stops the disc at approximately 2/3 lever travel.
7. Minor adjustment can be made by turning the Adjusting Barrel on the brake lever or the Adjusting Barrel (C) on the Caliper. Turn the Adjusting Barrel OUT to tighten the brakes or IN to loosen the brakes.

NOTE: Make sure the Adjusting Barrel threads are fully engaged. Check adjustment again.

8. If you cannot reduce the gap by turning the Adjusting Barrel, the brake pads might be worn out and need to be replaced.

PAD REPLACEMENT:

1. Remove the Caliper Mounting Bolts (F).
2. Remove the Caliper assembly (E).
3. Remove the Brake Pads from the Caliper.
4. Install the new Brake Pads using same type, material, and size.
5. Install the Caliper assembly (E) to the mounts on the fork (front), or frame (rear) (front shown).
6. Tighten the caliper Mounting Bolts (F) securely.
7. Route the Cable (D) through the lower Adjusting Barrel (C) and Cable Clamp (A).
 - Ensure Cable Housing (G) is fully inside Adjusting Barrel (C).
8. Pull the Cable through the Cable Clamp, and tighten the Clamp (A) Bolt.

NOTE: Brake adjustment involves loosening the Cable Clamp Bolt. During installation, it only needs to be tightened enough to make sure the Cable End doesn't pull back through the Camp.

9. Adjust the Brake (as described above).

BRAKE SYSTEM MAINTENANCE:

- Check brake operation and adjustment before each ride.
- Keep the brake system free of dirt, mud, oil, and other foreign substances that will inhibit proper operation.
- Frequently check:
 - All components for damage.
 - The pads - for wear.
 - The lever - for smooth operation.
 - The cable - ensure there are no frayed ends, cuts, or kinks that inhibit operation. Add cable lube if the cable is dry.
 - All bolts and fasteners - ensure the bolts are tightened, replace any that are damaged.

NOTE: These are general instructions. Please refer to component manufacturer's documentation for product specific instructions.

WARNING:

- Do not over lubricate. If oil gets on the wheel rims or the brake shoes, it will reduce brake performance and a longer distance to stop the bicycle will be necessary. Injury to the rider or to others can occur.
- The chain can throw excess oil onto the wheel rim. Wipe excess oil off the chain.
- Keep all oil off the surfaces of the pedals where your feet rest.
- Using soap and hot water, wash all oil off the wheel rims, the brake shoes, the pedals, and the tires.
- Rinse with clean water and dry completely before you ride.
- Using a light machine oil (20 W), lubricate the bicycle according to the following table:

Lubrication Table (as equipped)

What	When	How
Pedals	every six months	Put four drops of oil where the axles go into the pedals.
Chain	every six months	Put one drop of oil on each roller of the chain. Wipe all excess oil off the chain.
Derailleurs	every six months	Put one drop of oil on each pivot point of the derailleurs.
Brake Levers	every six months	Put one drop of oil on the pivot point of each brake lever.
Wheel Brakes	every six months	Put one drop of oil on the pivot point of each cantilever brake.
Brake and cable	every six months	Put four drops of oil into both ends of each cable. Allow oil to soak back along the cable wire.
Rear Sprocket Cluster	every six months	Lay the bicycle on its left side. Slowly turn the rear wheel clockwise. Put four drops of oil in the crack between the rear sprockets (which are stationary) and the freewheel body (which is turning clockwise).
Shock Fork	every six months	Lift up the rubber fork boot and dab a small amount of grease on the fork leg just above the plastic bushing.

Inspection of the Bearings

Maintenance:

Frequently check the bearings of the bicycle. Have a bicycle service shop lubricate the bearings once a year or any time they do not pass the following tests:

Headset Bearings:

The fork should turn freely and smoothly at all times. With the front wheel off the ground, you should not be able to move the fork up, down, or side-to-side in the head tube.

Crank Bearings:

The crank should turn freely and smoothly at all times and the front sprockets should not be loose on the crank. You should not be able to move the pedal end of the crank from side-to-side.

Wheel Bearings:

Lift each end of the bicycle off the ground and slowly spin the raised wheel by hand. The bearings are correctly adjusted if:

- The wheel spins freely and easily.
- The weight of the spoke reflector, when you put it toward the front or rear of the bicycle, causes the wheel to spin back and forth several times.
- There is no side-to-side movement at the wheel rim when you push it to the side with light force.



IMPORTANT! Before using the unit for the first time the battery needs to be charged for at least **3.5 to 5 hours - no more than 12 hours**. Battery Charger will shut off when Battery is fully charged.

NOTE: Your e-Bike Li-Ion Battery can be charged either installed in the bike or removed.

IMPORTANT!

- All large Li-Ion batteries are a potential fire risk and should be charged in a safe place, preferably outside or in the middle of a garage floor. Never charge a lithium battery unsupervised inside a house or building.
- Only an adult who has read and understands the safety warnings should handle, charge or recharge of the battery.
- Check the drive battery and charger (supply cord, connector) for wear and damage before charging. Do not charge the battery if damage has occurred. Only replace with the same type and voltage rechargeable battery and charger supplied by the manufacturer.
- Only use the rechargeable battery (or equivalent replacement) and charger supplied with your vehicle.
- The drive battery should be charged when depleted, or if not used regularly, once a month. Failure to charge the battery as directed will cause permanent damage to the battery and will void the warranty.
- Charge only when battery has cooled to room temperature after a ride.

STEPS:

NOTE: Battery can also be removed before charging.

1. Turn power OFF.
 2. Locate the Charging Port cover (A) on side of bike frame and open.
 3. Plug Charger plug into unit Charging Port (B).
- **CAUTION:** Charger plug is keyed to only fit one way - **do not force**.
4. Plug Charger into Wall outlet.
 5. When battery is fully charged, un-plug charger from the wall outlet and disconnect from charger port - close charging port cover (A).

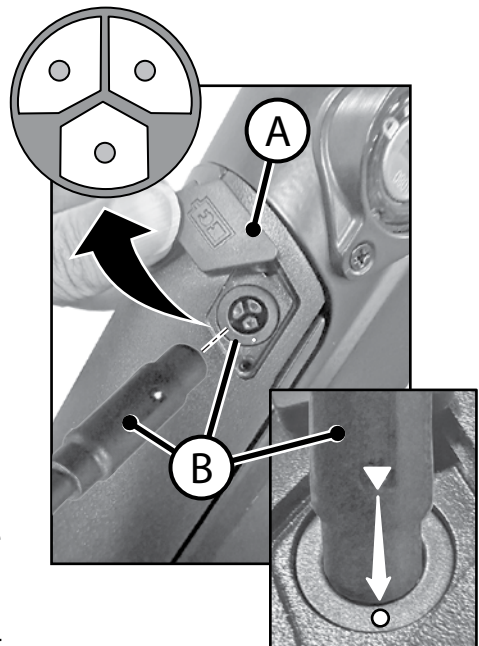

NOTES:

- The charger may feel warm during the charging. If excessively hot, unplug and replace.
- This product has charging protection: When charging, all functions are turned OFF.

Lithium-Ion Battery Storage and Disposal

Do not leave batteries unused for extended periods of time, either in the product or in storage. When a battery has been unused for 6 months, check the charge status and charge or dispose of the battery as appropriate.

STORAGE:

- Charge or discharge the battery to approximately 50% of capacity before storage.
- Charge the battery to approximately 50% of capacity at least once every six months.
- Remove the battery and store it separately from the product.
- Store the battery at temperatures between 41°F - 68°F (5°C - 20°C).
- Do not store battery in extreme hot or cold temperatures.
- Wipe the battery clean with a dry cloth prior to storage. Wash cloth separate from other clothes.

BATTERY MAINTENANCE:

Observe and note the run time that a new fully-charged battery provides for powering your product. Use this new battery run time as a basis to compare run times for older batteries. The run time of your battery will vary depending on the product's configuration and the applications that you run.

- Routinely check the battery's charge status.
- Carefully monitor batteries that are approaching the end of their estimated life.
- Consider replacing the battery with a new one if you note either of the following conditions:
 - The battery run time drops below about 80% of the original run time.
 - The battery charge time increases significantly
- Discontinue use and have the battery checked or replaced in the following conditions:
 - There is a change in the shape or color of the battery.
 - There is a strange odor or noise associated with the battery.
 - The battery overheats or leaks.

BATTERY DISPOSAL:

- Lithium-Ion batteries must be recycled or disposed of in an environmentally sound manner.
- Lithium-Ion batteries are subject to disposal and recycling regulations that vary by country and region. Always check and follow your applicable regulations before disposing of any battery.
- Do not dispose of battery in a fire. The battery may explode or leak acid.
- Do not dispose of the battery in household trash. The incineration, land filling or mixing of sealed Li-ion/lead-acid batteries with household trash is prohibited by law.
- Return an exhausted battery to a federal or state approved Li-ion/lead-acid battery recycler. (check local battery disposal regulations).

Tires

Maintenance:

- Frequently check the tire inflation pressure because all tires lose air slowly over time. For extended storage, keep the weight of the bicycle off the tires.
- Do not use unregulated air hoses to inflate the tire/tubes. An unregulated hose can suddenly over inflate bicycle tires and cause them to burst.
- Replace worn tires.

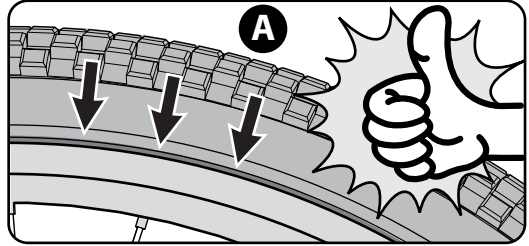

⚠ WARNING: Do not ride or sit on the bicycle if a tire is under inflated. This can damage the tire, inner tube and rim.

INFLATING THE TIRES:

- Use a hand or a foot pump to inflate the tires.
- Service station meter-regulated air hoses are also acceptable.
- The maximum inflation pressure is shown on the tire sidewall.

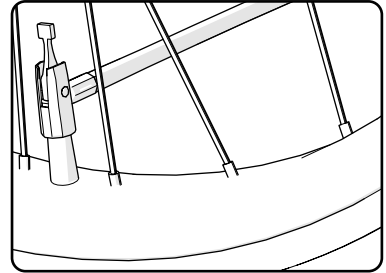

NOTE: Inflate tire to 50% of the recommended PSI range. Make sure the edge of the tire (the bead) is the same distance from the rim, all around the rim, on both sides of the tire **A**. If the tire does not appear to be seated correctly, release air from the inner tube until you can push the bead of the tire into the rim where necessary. Add air slowly and stop frequently to check the tire seating and the pressure, until you reach the correct inflation pressure.

Recommended Tire Pressure (kilopascals):

Frequently check the tire inflation pressure because all tires lose air slowly over time. For extended storage, keep the weight of the product off the tires.

Recommended tire pressure is marked on the side of the tire.

PSI	Kpa
20	140
30	210
40	275
50	345
60	415

Tire and Tube Installation

STEP 1 - REMOVE EXISTING TIRE AND TUBE:

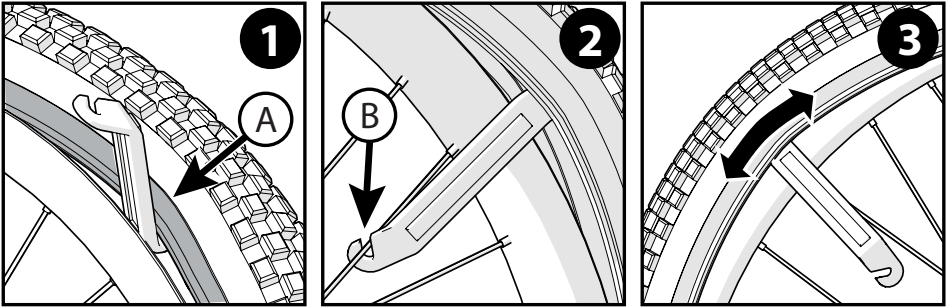

STEPS (start opposite Filler Valve):

1. Squeeze deflated tire inwards and insert Tire Lever under Tire Bead (A).
2. Hook end of Tire Lever on a Spoke (B).
3. Insert second Tire Lever and slide along rim to remove tire bead.
4. Remove Inner Tube and Tire.
5. Inspect for cause of flat and remove any foreign object from the tire if necessary.

STEP 2 - INSTALLING NEW TIRE AND TUBE:

1. Using your hands, start with one Bead (A) of Tire (B) and install it all the way around Rim (C).
2. Insert a slightly inflated Inner Tube (D) into the Tire and make sure the Valve Stem (E) is straight and aligned with the Rim Hole.
3. Work the second Tire Bead onto the Rim all the way around. This will take a little more effort than the first Tire Bead did. Use Tire Lever Tools if needed.
4. **Make sure the Tube does not get pinched between Rim and Tire.**
5. Inflate Tire just enough that it takes shape.
6. Double check that both Tire Beads are seated properly and that the Valve Stem is pointing straight out.
7. Fully inflate tube to recommended pressure listed on Tire side wall - **do not over-inflate.**
8. Install Valve Cap.

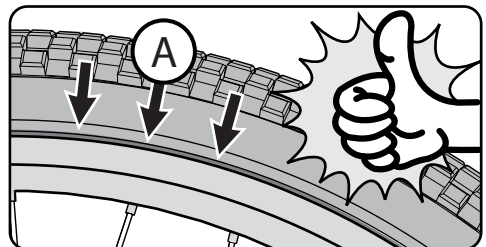
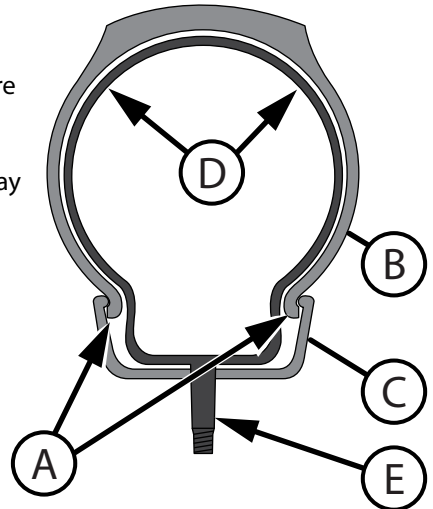

Troubleshooting

Symptoms	Possible Cause	Solution
Display is on, motor does not work or works slowly/intermittently	Battery voltage is low	Charge Battery
	Battery is loose in compartment	Re-seat Battery
	Wire Harness connectors loose	Check that Harness connectors are firmly attached
Reduced ride time	Battery is low	Recharge
	Battery does not hold a charge	Replace Battery
Battery does not fully charge	Battery at end of life	Replace Battery
	Charger not connected correctly	Re-check charger connections at battery and wall socket
	Battery not fully seated	Re-seat Battery
Display does not turn on	Wire Harness connectors loose	Check that Harness connectors are firmly attached
	Display bad	Replace Display
	Power is off	Turn Power on
No Pedal assist	Wire Harness connectors loose	Check that Drive Motor Harness connectors are firmly attached
	Motor bad	Replace Motor
	Speed sensor magnet not aligned	Align magnet on wheel with sensor on frame near motor

Limited Warranty - EN

General:

Part or model specifications are subject to change without notice.

This Limited Warranty is the only warranty for the product. ALL WARRANTIES OTHER THAN STATED HEREIN ARE DISCLAIMED INCLUDING IMPLIED WARRANTIES OF MERCHANTABILITY AND FITNESS FOR A PARTICULAR PURPOSE, TO THE EXTENT ALLOWABLE BY APPLICABLE LAW. ALL LIABILITY FOR INCIDENTAL, PUNITIVE, SPECIAL, OR CONSEQUENTIAL DAMAGES ARE EXPRESSLY DISCLAIMED, TO THE EXTENT ALLOWABLE BY APPLICABLE LAW.

The only uses for this product are described in this manual.

Warranty registration is not required.

The Limited Warranty extends only to the original consumer and is not transferable to anyone else.

What does this Limited Warranty cover?

This Limited Warranty covers defects in workmanship and materials for all parts of the product except those indicated below as not warranted.

What must you do to keep the Limited Warranty in effect?

This Limited Warranty is effective only if:

- Product is completely and correctly assembled.
- Product is used under normal conditions for its intended purpose (see the following section for excluded activities).
- Product receives all necessary maintenance and adjustments.
- Product is used for general transportation and recreational use only.

What is not covered by this Limited Warranty?

This product is designed for recreational use only. This Limited Warranty does not cover normal wear and tear, normal maintenance items, or any damage, failure, or loss that is caused by improper assembly, maintenance, adjustment, storage, or use of the product. This Limited Warranty does not extend to future performance.

This Limited Warranty will be void if the product is ever:

- Used in any competitive sport.
- Used for stunt riding, jumping, aerobatics or similar activity.
- Modified in any way.
- Modified with the addition of a motor.
- Ridden by more than one person at a time.
- Exceeds weight limit.
- Rented, sold, or given away.
- Used in a manner contrary to the instructions and warnings in this Owner's Manual.

What will The Manufacturer do?

Manufacturer's sole and exclusive obligation under this Limited Warranty is to repair and/or replace, at its sole option, any covered defect in workmanship or materials.

How do you get service?

Contact the Customer Service Department.

- See included list for Customer Contact information.

What rights do you have?

This Limited Warranty gives you specific legal rights. You may also have other rights which vary from State to State.

For how long does this Limited Warranty last?

- When used in this Limited Warranty, the phrase "for life" means for as long as the original consumer owns the product.
 - The frame is warranted for life except Aluminum/Carbon frames which are warranted for ten (10) years.
 - The fork is warranted for life except for shock forks which are warranted one (1) year.
 - Drive Battery - 2 years
 - Electronics - 2 years
 - All other Components - 6 months
- All warranties are from the date of delivery.

[USA]



**PLEASE - BEFORE RETURNING TO STORE:
Contact Huffy Customer Service.
We are glad to assist you
with any parts or assembly problems you might have!**

For Fast Customer Service and email:

www.huffybikes.com/contact

OR TEL: 1 800 872 2453 (US)

8877 Gander Creek Drive
Miamisburg, OH 45342

To Order Parts:

www.huffybikes.com/parts

[CANADA]

**PLEASE - BEFORE RETURNING TO STORE:
Contact Huffy Customer Service.**

We are glad to assist you with any parts or assembly problems you might have!

AVANT DE RETOURNER AU MAGASIN :

**Communiquez avec le service à la clientèle de Huffy. Nous vous aiderons
volontiers avec tout problème concernant les pièces ou le montage!**

For fast customer service in Canada / Pour un service à la clientèle rapide au Canada :

Call / Appelez : 1-800-872-2453

Or Email / Ou Courriel : huffycanada@huffy.com

Or visit / Ou visitez : : www.huffybikes.com/global-contacts

[MÉXICO]

ANTES DE DEVOLVER EL PRODUCTO A LA TIENDA:

**Comuníquese Con Servicio Al Cliente De Huffy. Nos Complace Ayudarlo Con
Cualquier Parte O Problema De Ensamblado Que Pudiera Tener.**

Para obtener Servicio al cliente rápido, visite:

www.huffybikes.com.mx

O LLAME AL TEL:

800 1 HUFFY 1 (800 1 48339 1)

(Mexico only)

Para comunicarse por correo electrónico:

servicio.mexico@huffy.com



For ASSEMBLY Help:
Aide à l'ASSEMBLAGE :
Ayuda de la ASAMBLEA:

<https://www.huffybikes.com/global-contacts/>



for current contact information /
pour les informations de contact
actuelles / para obtener la
información de contacto actual

Please REGISTER your Product:
Veuillez ENREGISTRER l'article :
Por favor, REGISTRE su producto:

